

## LIMBACH L1700 E0/EC, L2000 E0/EC

Four cylinder, horizontally opposed air cooled engine, with single magneto ignition, wet sump pressure lubrication

### L 1700 E0 / EC:

Maximum HP (5 min) 68 hp / 50 kW / 3600 rpm  
 Continous HP 60 hp / 44 kW / 3200 rpm  
 Bore 88 mm / 3.46 inch  
 Stroke 69 mm / 2.71 inch  
 Displacement 1680 cm<sup>3</sup> / 102.52 cub. in.  
 Compression ratio 8 : 1

### L 2000 E0 / EC:

Maximum HP (5 min) 80 hp / 59 kW / 3400 rpm  
 Continous HP 70 hp / 51 kW / 3000 rpm  
 Bore 90 mm / 3.54 inch  
 Stroke 78.4 mm / 3.09 inch  
 Displacement 1994 cm<sup>3</sup> / 121.68 cub. in.  
 Compression ratio 8.4 : 1  
 Magneto Slick 4330  
 Harness Slick High Temperature  
 Spark plugs Eyquem A 755  
 Electrode spacing 0.5 mm  
 Firing order 1 - 3 - 2 - 4  
 Firing point 30° BTDC  
 Carburator Zenith 150 CD-3  
 Fuel min. octane 98 RON (Unleaded) or AVGAS 100LL  
 Air cleaner LIMBACH

Mechanical fuel pump APG-LIMBACH  
 Starter with solenoid 12 V - 1.1 kW  
 Generator 14 V - 33 A or 14 V - 55 A  
 Oil pressure max. 4 bar; min. 1 bar at 2500 rpm  
 Oil temperature max. 120 °C; min. 50 °C  
 Oil capacity 2.5 ltrs  
 Cylinder head temp. max. 250 °C  
 Tachometer drive mechanical  
 Propeller drive direct, anti-clockwise  
 Propeller hub E01/EC1 for variable pitchΩ  
 E02/EC2 for fixed pitchΩ  
 Dry weight approx. L 2000 E0: 74 kg  
 L 1700 E0: 73 kg  
 Fuel consumption should be individually established during flight tests, however the average fuel consumption is approx.:  
 10 ltrs/hr L 1700 E0 / EC  
 12 ltrs/hr L 2000 E0 / EC  
 LBA Type Certificate No. 4582 (JAR 22-H) L 1700 E0 / EC  
 4597 (JAR 22-H) L 2000 E0 / EC

**Limbach Flugmotoren GmbH & Co.KG**  
 Kotthausener Straße 5  
 D-53639 Königswinter-Sassenberg  
 Tel. ++49-2244/9201-0  
 Fax ++49-2244/9201-30  
 E-Mail: sales@limflug.de  
 www.limflug.de

**Frontansicht**

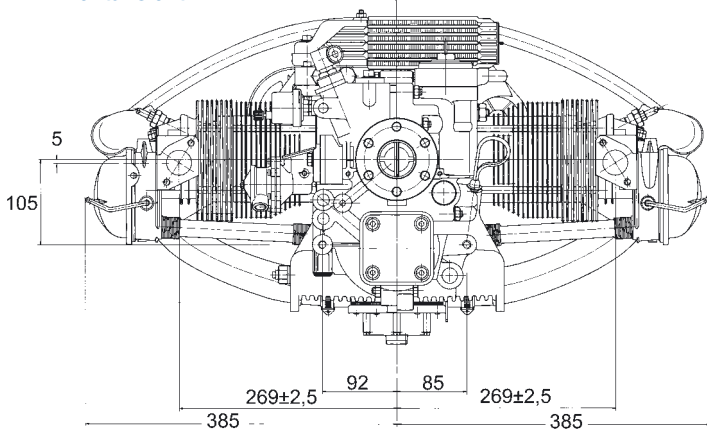

**Seitenansicht**

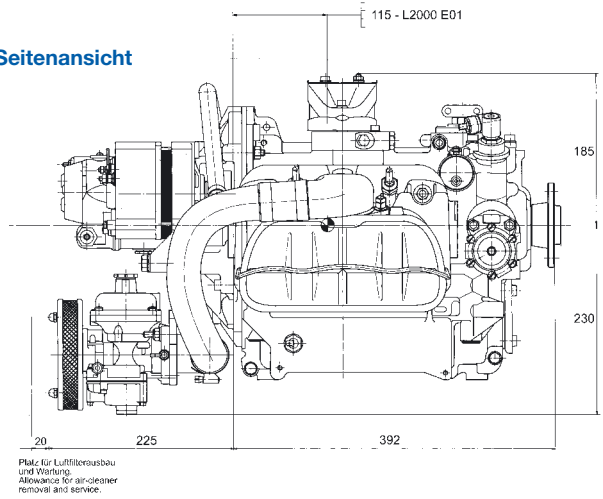

**Draufsicht**

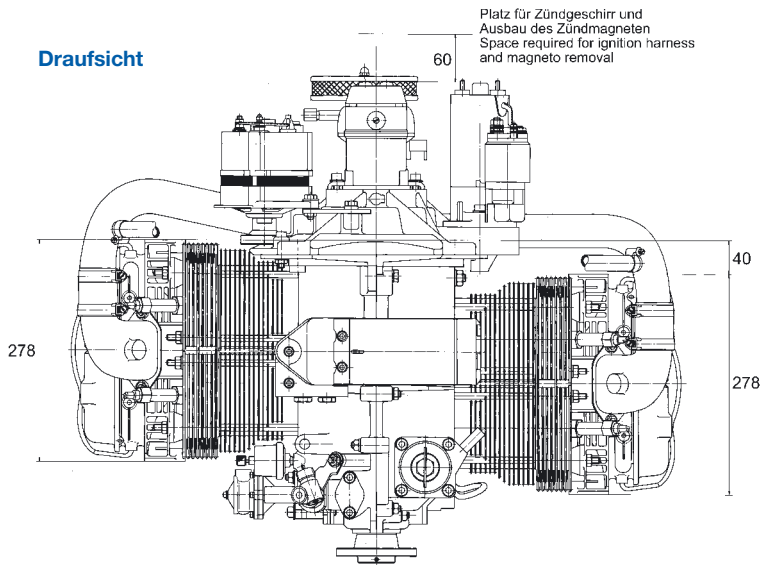

**Rückansicht**

